

*...you'll never drive alone*

[www.j4europe.com](http://www.j4europe.com)



**MAN**

suitable for

**QTC**® QUALITY  
TRUCK  
COMPONENTS

**EDITION 2020**

**TGX 2013**

**TGS 2013**

**TGX 2007 - 2012**

**TGS 2007 - 2012**

**TGA XL-XXL**

**TGA M-L-LX**

**F2000**

**TGL**

**LE2000**

page 3

page 5

page 7

page 9

page 10

page 16

page 18

page 23

page 24

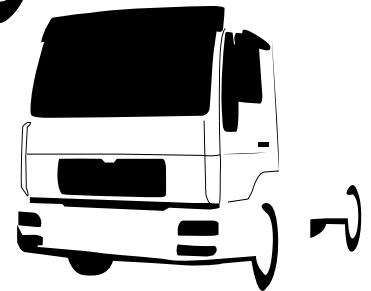

SUITABLE FOR **MAN TGX 2013**

M6X/108 RH



M6X/109 LH



M6X/106 RH



M6X/106G RH



M6X/107G LH



M6X/107 LH



M6X/102 RH



M6X/102G RH



M6X/103G LH



M6X/103 LH



M6X/115



M6X/115G



SUITABLE FOR **MAN TGX 2013**

M6X/108 RH



M6X/109 LH



M6X/104 RH



M6X/104G RH

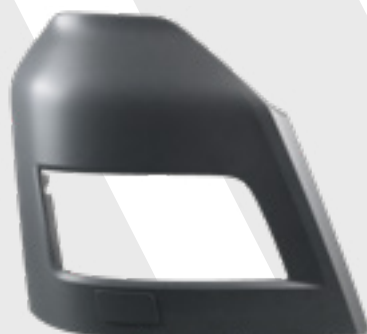

M6X/105G LH



M6X/105 LH



M6X/122 KIT

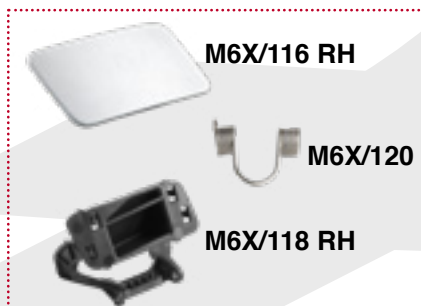

M6X/122G KIT

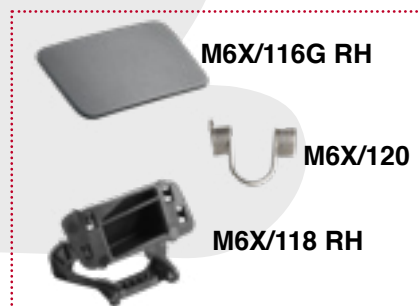

M6X/123G KIT



M6X/123 KIT



SUITABLE FOR **MAN TGS 2013**

M6X/108 RH



M6X/109 LH



M6S/106 RH

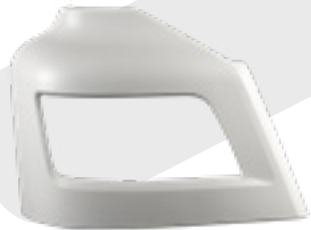

M6S/106G RH



M6S/107G LH



M6S/107 LH



M6S/102 RH



M6S/102G RH



M6S/103G LH



M6S/103 LH



M6S/115



M6S/115G



SUITABLE FOR **MAN TGS 2013**

**M6X/108 RH**



**M6X/109 LH**



**M6S/104 RH**



**M6S/104G RH**

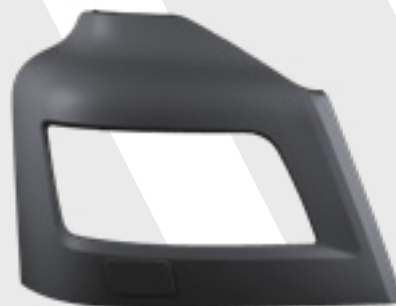

**M6S/105G LH**



**M6S/105 LH**



**M6X/122 KIT**

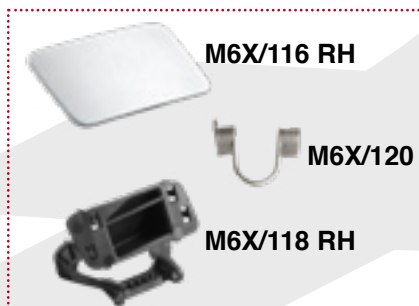

**M6X/122G KIT**

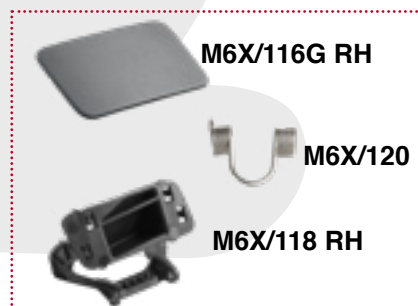

**M6X/123G KIT**



**M6X/123 KIT**



SUITABLE FOR **MAN TGX 2007 - 2012**



MTX/180 GREY  
MTX/180K KIT



MTX/710 RH



MTX/100K kit

MTX/100

MTX/116 RH



MTX/115 LH



MTX/711 LH



MTX/706 RH  
MTX/706X RH (XENON)



MTX/707 LH  
MTX/707X LH (XENON)



MTX/722 RH



MXX/183



MXX/183



MTX/723 LH



MTX/182 RH



MTX/181 LH





SUITABLE FOR **MAN TGX** 2007 - 2012



**MTX/300 RH**



**MTX/301 LH**



**MTX/311 RH - LH**



**MTX/304 RH**



**MTX/305 LH**



**MTX/309 RH - LH**



SUITABLE FOR **MAN TGS** 2007 - 2012



**MTS/350 RH \***



**MXX/356**



**MTS/351 LH \***



**MTS/182 RH**



**MTS/181 LH**



**\* MXX/356 INCLUDED**

# SUITABLE FOR MAN TGA XL - XXL 2002 - 2007

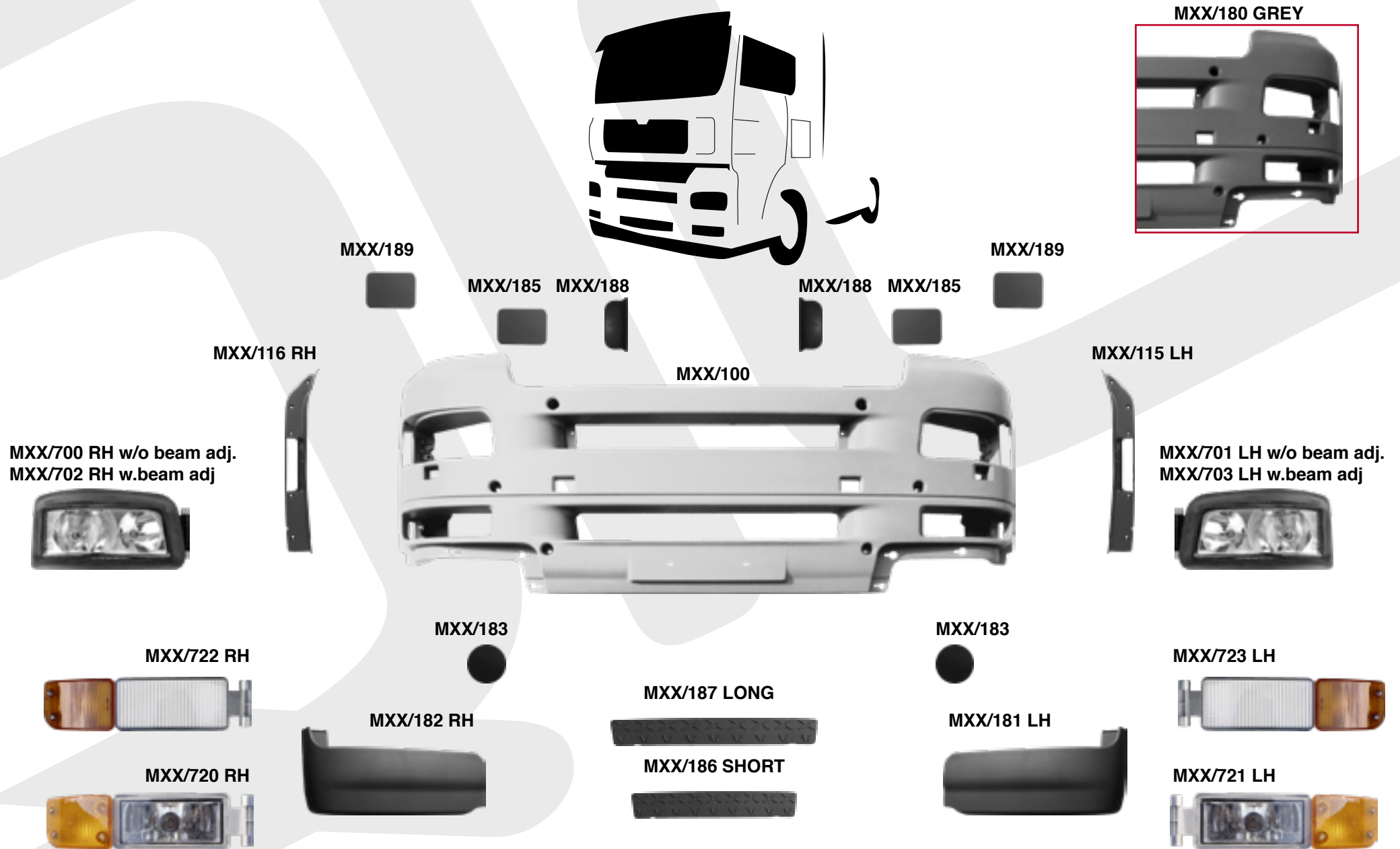

SUITABLE FOR **MAN TGA XL - XXL 2002**



**MXX/260 RH**



**MXX/261 LH**



**MXX/262 RH**



**MXX/263 LH**



**MXX/201**



**MXX/264 RH**



**MXX/265 LH**



**MXX/200**



**MXX/216**



**MXX/217**



**SHINY CHROMED VERSION**

SUITABLE FOR **MAN TGA XL - XXL 2002**



**MXX/302 RH**



**MXX/303 LH**



**MXX/306 RH GREY**



**MXX/307 LH GREY**



**MXX/304 RH**

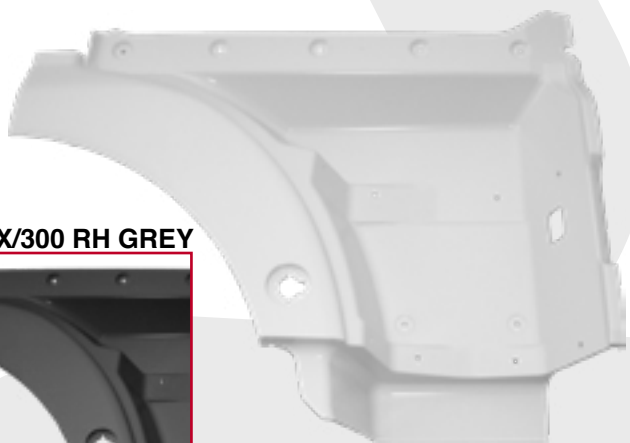

**MXX/305 LH**

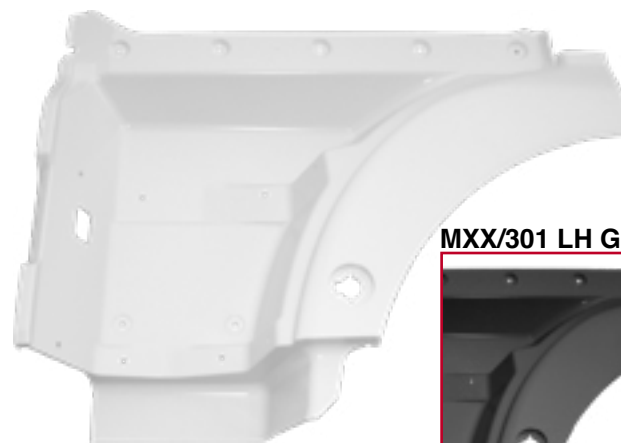

**MXX/300 RH GREY**



**MXX/301 LH GREY**



**MXX/308 RH-LH**



**MXX/309 RH-LH**



SUITABLE FOR **MAN TGA XL - XXL 2002**



**MXX/355**



**MXX/350 RH \***

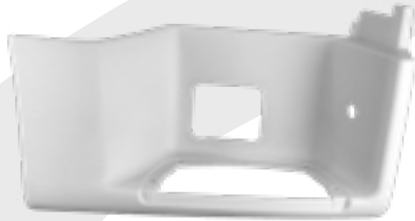

**MXX/351 LH \***

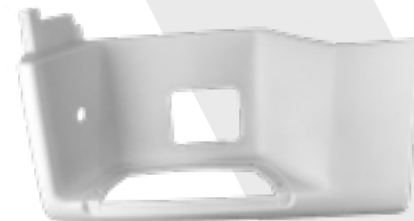

**MXX/310 RH-LH**

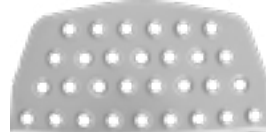

**MXX/352 RH GREY \*\***



**MXX/353 LH GREY \*\***



**MXX/356**



**\* MXX/355 INCLUDED \*\* MXX/356 INCLUDED**

SUITABLE FOR **MAN TGA XL - XXL 2002**



**MXX/370 RH**



**MXX/371 LH**



**MXX/362 RH**



**MXX/360 RH-LH**



**MXX/363 LH**



SUITABLE FOR **MAN TGA XL - XXL / TGX / TGS**

MTX/400



MTX/415



MXX/400

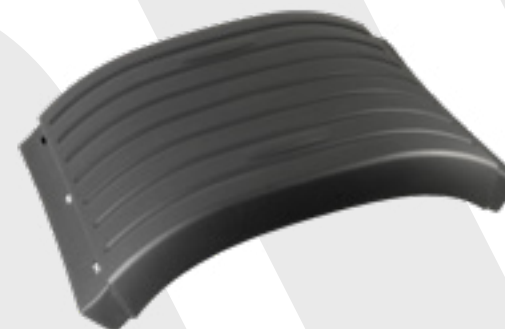

MXX/415



MTX/402 RH - LH \*



MTX/402  
REAR VIEW



MTX/445  
H 95 cm

MXX/402 LH-RH FRONT/REAR



MXX/403 LH-RH FRONT/REAR



MTX/401 RH - LH \*



MTX/475



\* MTX/475 INCLUDED



SUITABLE FOR **MAN TGA M - L - LX 2002**



**MML/180 GREY**



**MML/100**



**MML/116 RH**



**MML/115 LH**



**MML/182 RH**



**MML/186**



**MML/181 LH**



SUITABLE FOR **MAN TGA M - L - LX 2002**



**MTS/350 RH \***



**MTS/351 LH \***



**MML/356**



**MXX/310 RH-LH**

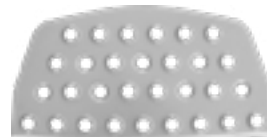

**MML/350 RH \*\***



**MML/351 LH \*\***



**MML/355**



**\* MML/356 INCLUDED \*\* MML/355 INCLUDED**

# SUITABLE FOR MAN F2000 1994

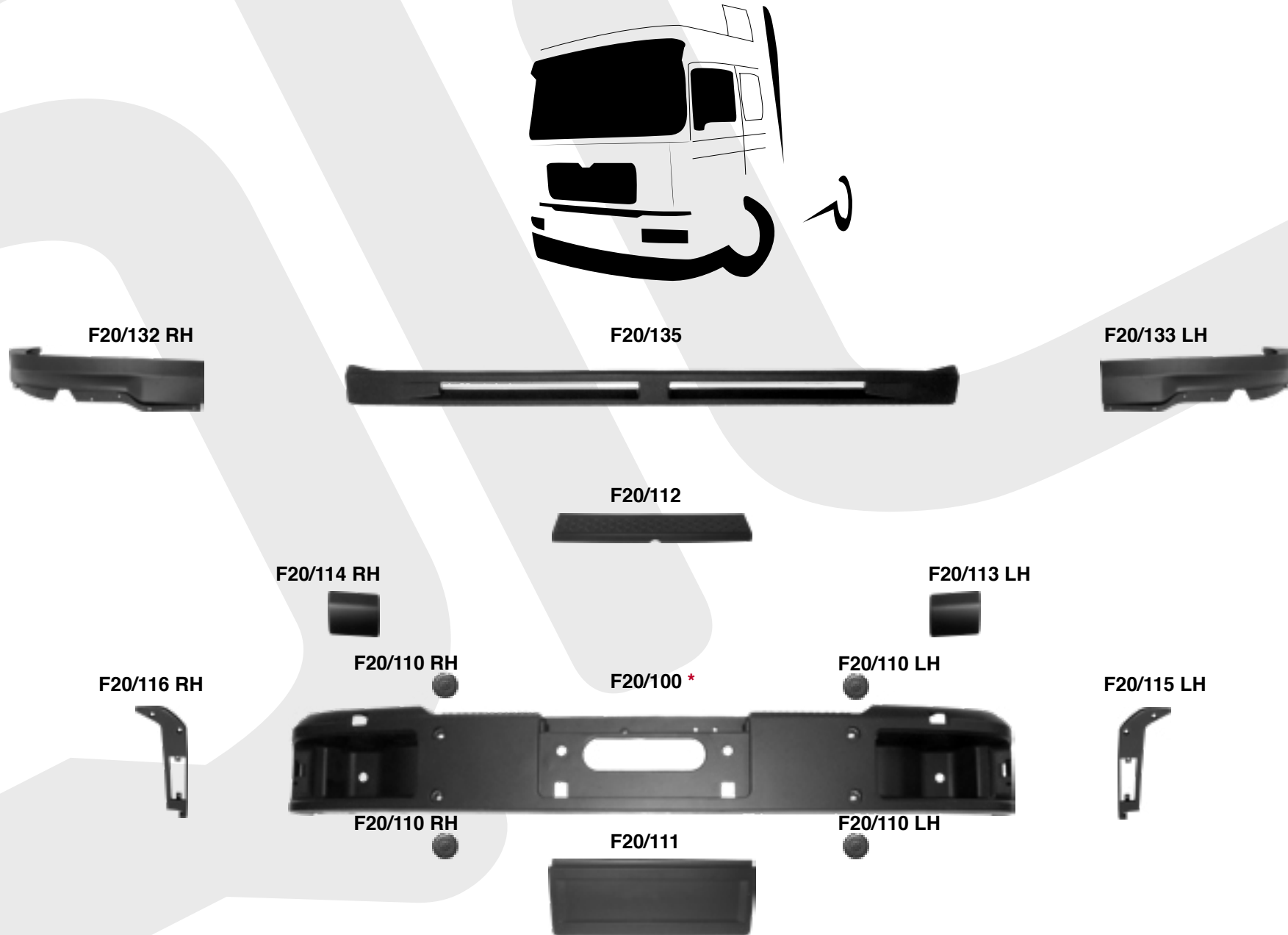

\* F20/111 - 112 - 113 - 114 - 115 - 116 INCLUDED

SUITABLE FOR **MAN F2000 1994**

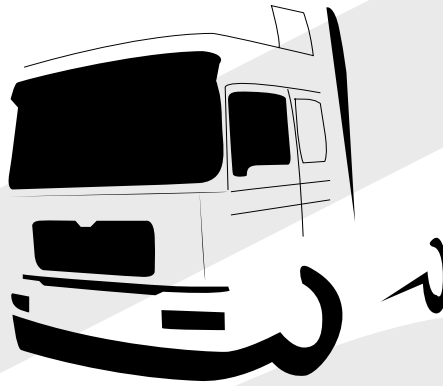

F20/105



F20/130



F20/146 RH

F20/104

F20/147 LH



F20/122 RH

F20/123 LH



F20/142 RH

F20/102

F20/143 LH



# SUITABLE FOR MAN F2000 1994

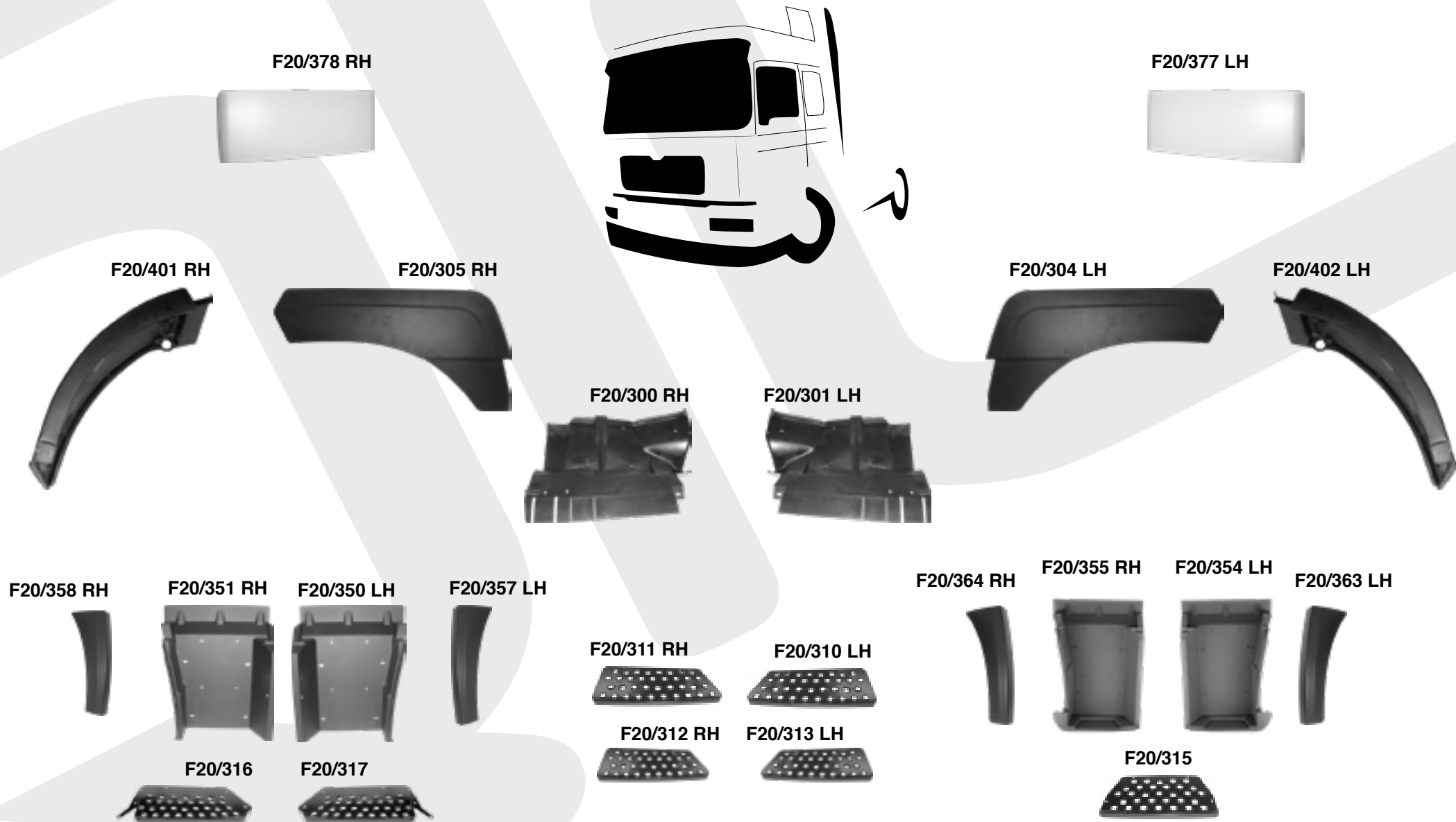

# SUITABLE FOR MAN F2000 1994

F20/386 RH



BACK AND FRONT VIEW

F20/382 RH



F20/384 RH-LH



F20/371 RH-LH



set of two outer handles with keys

F20/369 LH



F20/381 RH



F20/399 LH

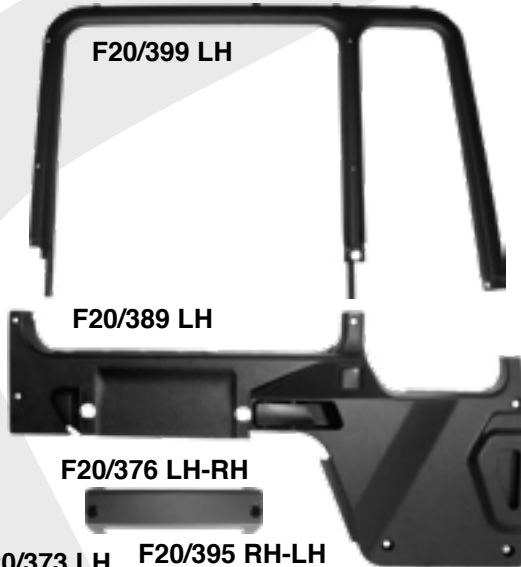

F20/389 LH

F20/376 LH-RH

F20/373 LH

F20/395 RH-LH



F20/398 RH

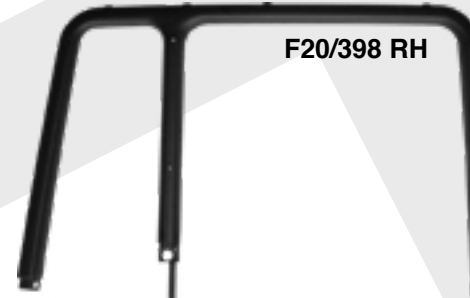

F20/388 RH

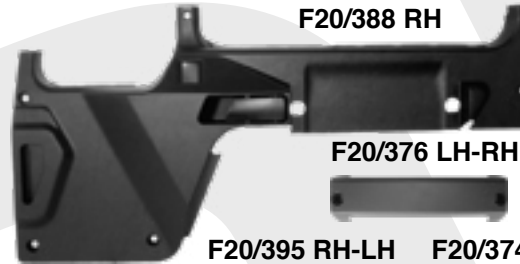

F20/376 LH-RH



F20/395 RH-LH

F20/374 RH



F20/380 LH



F20/368 RH



F20/385 LH



BACK AND FRONT VIEW

F20/383 LH



F20/384 RH-LH



# SUITABLE FOR MAN F2000 1994

F20/262 RH



F20/260 RH



F20/205 RH



F20/500



F20/205 LH



F20/261 LH



F20/263 LH



F20/201



F20/CH6



F20/200

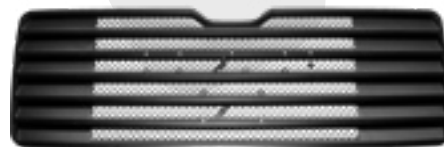

F20/CH2



F20/CH3



F20/CH5



SUITABLE FOR **MAN TGL 2005**

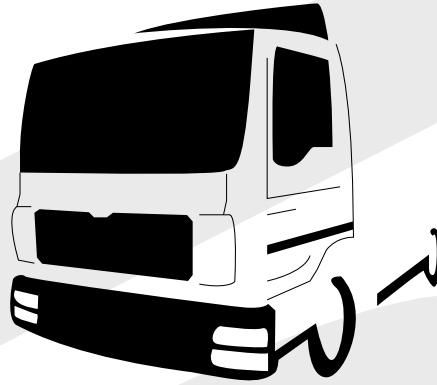

**MTL/300 RH**



**MTL/301 LH**



**MTL/100**



**MXX/310**

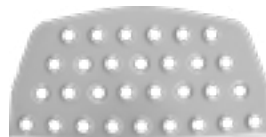

**MML/186**





SUITABLE FOR **MAN LE 2000 1992**



L20/300 RH



L20/301 LH



LE2/180





**MAN TGX 2013**

QTC	OEM	PAG
<b>M6X/102</b>	81416106754	3
<b>M6X/102G</b>	81416106774	3
<b>M6X/103</b>	81416106755	3
<b>M6X/103G</b>	81416106775	3
<b>M6X/104</b>	81416106752	4
<b>M6X/104G</b>	81416106772	4
<b>M6X/105</b>	81416106753	4
<b>M6X/105G</b>	81416106773	4
<b>M6X/106</b>	81416106750	3
<b>M6X/106G</b>	81416106770	3
<b>M6X/107</b>	81416106751	3
<b>M6X/107G</b>	81416106771	3
<b>M6X/108</b>	81416106760	3 - 4
<b>M6X/109</b>	81416106759	3 - 4
<b>M6X/115</b>	81416140076	3
<b>M6X/115G</b>	81416140080	3
<b>M6X/116</b>	81416100532	4
<b>M6X/116G</b>	81416100532	4
<b>M6X/117</b>	81416100533	4
<b>M6X/117G</b>	81416100533	4
<b>M6X/118</b>	81416100575	4
<b>M6X/119</b>	81416100744	4
<b>M6X/120</b>	81976300196	4
<b>M6X/122</b>		4
<b>M6X/122G</b>		4
<b>M6X/123</b>		4
<b>M6X/123G</b>		4

**MAN TGS 2013**

QTC	OEM	PAG
<b>M6S/102</b>	81416106766	5
<b>M6S/102G</b>	81416106802	5
<b>M6S/103</b>	81416106765	5
<b>M6S/103G</b>	81416106803	5
<b>M6S/104</b>	81416106764	6
<b>M6S/104G</b>	81416106763	6
<b>M6S/105</b>	81416106800	6
<b>M6S/105G</b>	81416106801	6
<b>M6S/106</b>	81416106762	5
<b>M6S/106G</b>	81416106798	5
<b>M6S/107</b>	81416106761	5
<b>M6S/107G</b>	81416106799	5
<b>M6X/108</b>	81416106760	5 - 6
<b>M6X/109</b>	81416106759	5 - 6
<b>M6S/115</b>	81416140077	5
<b>M6S/115G</b>	81416140081	5
<b>M6X/116</b>	81416100532	6
<b>M6X/116G</b>	81416100532	6
<b>M6X/117</b>	81416100533	6
<b>M6X/117G</b>	81416100533	6
<b>M6X/118</b>	81416100575	6
<b>M6X/119</b>	81416100744	6
<b>M6X/120</b>	81976300196	6

**MAN TGX**

QTC	OEM	PAG
<b>MTX/100</b>	81416100364	7
<b>MTX/100K</b>	81416100364-81416100369-81416100370	7
<b>MTX/115</b>	81416100369	7
<b>MTX/116</b>	81416100370	7
<b>MTX/180</b>	81416100363	7
<b>MTX/180K</b>	81416100363-81416100369-81416100370	7
<b>MTX/181</b>	81416140025	7
<b>MTX/182</b>	81416140026	7
<b>MTX/300</b>	81615100914	8
<b>MTX/301</b>	81615100913	8
<b>MTX/304</b>	81615100916	8
<b>MTX/305</b>	81615100915	8
<b>MTX/309</b>	81615100930	8
<b>MTX/311</b>	81615100929	8
<b>MTX/706</b>	81251016498	7
<b>MTX/706X</b>	81251016516	7
<b>MTX/707</b>	81251016499	7
<b>MTX/707X</b>	81251016515	7
<b>MTX/710</b>	81251100084	7
<b>MTX/711</b>	81251100083	7
<b>MTX/722</b>	81251016522	7
<b>MTX/723</b>	81251016521	7
<b>MXX/183</b>	81416850029	7

**MAN TGS**

QTC	OEM	PAG
<b>MTS/181</b>	81416140023	9
<b>MTS/182</b>	81416140024	9
<b>MTS/350</b>	81615100644	9
<b>MTS/351</b>	81615100643	9
<b>MXX/356</b>	81615100536	9

MAN TGA XL-XXL		
QTC	OEM	PAG
<b>MXX/100</b>	81416100305	10
<b>MXX/115</b>	81416100231	10
<b>MXX/116</b>	81416100232	10
<b>MXX/180</b>	81416100306	10
<b>MXX/181</b>	81416100227	10
<b>MXX/182</b>	81416100228	10
<b>MXX/183</b>	81416850029	10
<b>MXX/185</b>	81416850031 - 81416850056	10
<b>MXX/186</b>	81416102881	10
<b>MXX/187</b>	81416102882	10
<b>MXX/188</b>	81416850041	10
<b>MXX/189</b>	81416850040 - 81416850055	10
<b>MXX/201</b>	81611100053	11
<b>MXX/216</b>	81416850053	11
<b>MXX/217</b>	81416850061	11
<b>MXX/260</b>	81624100046	11
<b>MXX/261</b>	81624100047	11
<b>MXX/262</b>	81624100048	11
<b>MXX/263</b>	81624100049	11
<b>MXX/264</b>	81624400041	11
<b>MXX/265</b>	81624400039	11
<b>MXX/300</b>	81615100400-81615100280-81615100404	12
<b>MXX/301</b>	81615100399-81615100281-81615100403	12
<b>MXX/302</b>	81626100024	12
<b>MXX/303</b>	81626100023	12
<b>MXX/304</b>	81615100402 - 81615100706	12
<b>MXX/305</b>	81615100401 - 81615100705	12
<b>MXX/306</b>	81626100018	12
<b>MXX/307</b>	81626100019	12
<b>MXX/308</b>	81615100273	12
<b>MXX/309</b>	81615110001	12
<b>MXX/310</b>	81615105187	13
<b>MXX/350</b>	81615100374 - 81615100752	13
<b>MXX/351</b>	81615100333 - 81615100751	13
<b>MXX/352</b>	81615100372	13
<b>MXX/353</b>	81615100311	13
<b>MXX/355</b>	81615100538	13
<b>MXX/356</b>	81615100536	13

MAN TGA XL-XXL		
QTC	OEM	PAG
<b>MXX/360</b>	81612100462	14
<b>MXX/362</b>	81664100308	14
<b>MXX/363</b>	81664100309	14
<b>MXX/370</b>	81615100410	14
<b>MXX/371</b>	81615100411	14
<b>MXX/400</b>	81664106086	15
<b>MXX/402</b>	81664100294	15
<b>MXX/403</b>	81664100293	15
<b>MXX/415</b>	81664100226	15
<b>MXX/700</b>	81251016448	10
<b>MXX/701</b>	81251016449	10
<b>MXX/702</b>	81251016450	10
<b>MXX/703</b>	81251016451	10
<b>MXX/720</b>	81253206112	10
<b>MXX/721</b>	81253206111	10
<b>MXX/722</b>	81253206090	10
<b>MXX/723</b>	81253206089	10
<b>MTX/400</b>	81664106606	15
<b>MTX/401</b>	81664106599	15
<b>MTX/402</b>	81664106625	15
<b>MTX/415</b>	81664400192	15
<b>MTX/445</b>	81664106674	15
<b>MTX/475</b>	81664400187	15

MAN TGA M-L-XL		
QTC	OEM	PAG
<b>MML/100</b>	81416100307	15
<b>MML/115</b>	81416100229	16
<b>MML/116</b>	81416100230	16
<b>MML/180</b>	81416100308	16
<b>MML/181</b>	81416100225	16
<b>MML/182</b>	81416100226	16
<b>MML/186</b>	81416102900	16
<b>MML/350</b>	81615100382 - 81615100740	17
<b>MML/351</b>	81615100355 - 81615100739	17
<b>MML/355</b>	81615100538 - 81615100822	17
<b>MML/356</b>	81615100823	17
<b>MTS/350</b>	81615100644	17
<b>MTS/351</b>	81615100643	17
<b>MXX/310</b>	81615105187	17

**MAN F2000**

QTC	OEM	PAG
F20/100	81416104114	18
F20/102	81416130073	19
F20/104	81416130071	19
F20/105	81416155061	19
F20/110	81960020425	18
F20/111	81416100150	18
F20/112	81416100191	18
F20/113	81416100159	18
F20/114	81416100158	18
F20/115	81416100151	18
F20/116	81416100152	18
F20/122	81416130066	19
F20/123	81416130069	19
F20/130	81416135035	19
F20/132	81416100166	18
F20/133	81416100167	18
F20/135	81416100164	18
F20/142	81416130078	19
F20/143	81416130079	19
F20/146	81416130080	19
F20/147	81416130081	19
F20/200	81611505060	22
F20/201	81611100043	22
F20/205	81748210095	22
F20/260	81624102224	22
F20/261	81624102225	22
F20/262	81624100064	22
F20/263	81624100063	22
F20/300	81612300066	20
F20/301	81612300067	20
F20/304	81612105363	20
F20/305	81612105364	20
F20/310	81615100267	20
F20/311	81615100268	20
F20/312	81615100262	20
F20/313	81615100263	20
F20/315	81615105181	20
F20/316	81615105196	20
F20/317	81615105197	20

**MAN F2000**

QTC	OEM	PAG
F20/350	81615100225	20
F20/351	81615100226	20
F20/354	81615100229	20
F20/355	81615100230	20
F20/357	81615105163	20
F20/358	81615105164	20
F20/363	81615105161	20
F20/364	81615105162	20
F20/368	81626406058	21
F20/369	81626406057	21
F20/371	81971006098	21
F20/373	81626410099	21
F20/374	81626410100	21
F20/376	81626410101	21
F20/377	81669120033	20
F20/378	81669120034	20
F20/380	81626004082	21
F20/381	81626004077	21
F20/382	81626806096	21
F20/383	81626806095	21
F20/384	81626800055	21
F20/385	81626806107	21
F20/386	81626806108	21
F20/388	81626306020	21
F20/389	81626306021	21
F20/395	81626416052	21
F20/398	81626300048	21
F20/399	81626300047	21
F20/401	81664100352	20
F20/402	81664100353	20
F20/500	81961210056	22
F20/CH2	81417015344	22
F20/CH3	81417015345	22
F20/CH5	81417226013	22
F20/CH6	81417226012	22

**MAN TGL**

QTC	OEM	PAG
MTL/100	81416100309 81416100352	23
MTL/300	81615100274 81615100820	23
MTL/301	81615100275 81615100821	23
MML/186	81416102900	23
MXX/310	81615105187	23

**MAN LE2000**

QTC	OEM	PAG
LE2/180	85416104032 85416104036	24
L20/300	85612100004	24
L20/301	85612100003	24

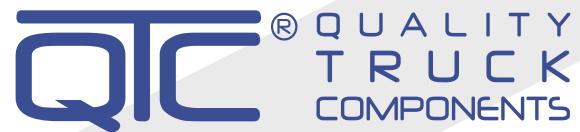

*...you'll never drive alone*

“I marchi utilizzati in questo catalogo sono proprietà dei fabbricanti dei veicoli industriali e commerciali a cui si riferiscono. Il loro utilizzo su questo catalogo serve unicamente per aiutare ad identificare il modello sul quale deve essere montato il pezzo di ricambio. I nostri articoli, pur non essendo originali, sono perfettamente intercambiabili ai veicoli a cui si riferiscono.”

“The property of the brand names used into this catalogue is exclusively of the makers. Original numbers used are for indication purpose only. Although our products are not original, they are perfectly interchangeable with them. “

“Les marques utilisées dans ce catalogue sont propriété des fabricants de véhicules industriels et commerciaux auxquels ils se réfèrent. Leur utilisation ne serve qu'à identifier le modèle sur lequel doit être montée la pièce de rechange. Nos articles, ne sont pas originaux, mais ils sont adaptables aux véhicules auxquels ils se rapportent “

“Die im vorliegenden Katalog verwendeten Marken sind Eigentum der Hersteller der Industrie- und Nutzfahrzeuge, auf die sie sich beziehen. Ihre Verwendung im vorliegenden Katalog dient ausschliesslich zur Identifizierung des Modells, in dem das Ersatzteil eingebaut werden soll. Unsere Artikel sind zwar keine Originalteile, aber dennoch perfekt austauschbar bei den Fahrzeuge, auf die sie sich beziehen “

“Znaki towarowe użyte w tym katalogu są własnością producentów pojazdów przemysłowych i użytkowych, do których się odnoszą. Numery OE w tym katalogu służą jedynie do właściwej identyfikacji części, oraz modelu w którym ta część zamienna może być zamontowana. Nasze artykuły, choć nie oryginalne, są doskonałe zamiennie z częściami oryginalnymi, do których się odnoszą “

“Τα εμπορικά σήματα που χρησιμοποιούνται σε αυτόν τον κατάλογο είναι ιδιοκτησία των κατασκευαστών των βιομηχανικών και εμπορικών οχημάτων στα οποία αναφέρονται. Η χρήση τους σε αυτόν τον κατάλογο χρησιμεύει μόνο για να βοηθήσει στον προσδιορισμό του μοντέλου στο οποίο πρέπει να montantato το ανταλλακτικό. Τα άρθρα μας, αν και δεν είναι πρωτότυπα, είναι απολύτως ανταλλάξιμα με τα οχήματα στα οποία αναφέρονται. “

“A propriedades das marcas usadas neste catálogo é dos fabricantes dos veículos. Codigos originais são usados apenas para indicação aos nossos clientes. Nossos produtos não são originais, mas perfeitamente intercambiáveis “

“Las marcas especificadas en este catalogo son propiedad de los fabricantes de vehículos industriales y comerciales referidos. El propósito de este catalogo es único y exclusivamente, para identificar el modelo en el cual se monta la pieza de ricambio suministrada por nosotros. Las referencias originales son utilizadas única y exclusivamente para su identificación por parte de nuestros clientes. Nuestros artículos no son originales pero perfectamente intercambiables“